

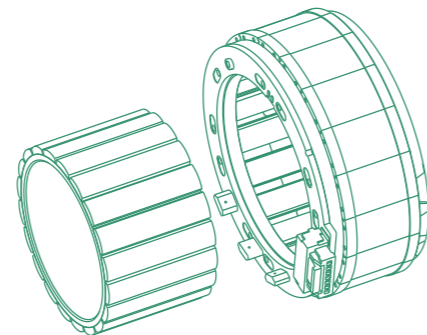

HIGH PERFORMANCE FRAMELESS MOTOR

高性能无框电机



ООО «ИнноДрайв» - официальный дистрибьютор Fulling motor в РФ

8 (812) 317-77-93
sales@innodrive.ru
www.innodrive.ru

常州富兴机电有限公司
Changzhou Fulling Motor Co.,Ltd

2024版

Company Profile - 公司简介

愿景 Vision

成为世界级的控制电机制造商及系统集成方案提供者

Become a world-class manufacturer of control motors and a provider of system integration solutions.

使命 Mission

为客户创造价值, 提供最优的行业解决方案

Create value for customers and provide the best industry solution.

价值观 Values

责任, 诚信, 共赢

Responsibility, Integrity and Win-win.

常州富兴机电有限公司是一家中、德、瑞合资企业, 成立于2001年, 位于中国常州。我们专业生产各类混合式步进电机, 直流无刷电机, 伺服电机及相关的驱动器, 年生产各类电机650万台以上, 另外我司有数家合资工厂, 专业生产各类永磁步进电机, 有刷直流电机, 二相、三相交流电机, 减速电机, 年销售各类电机总量超750万台。产品广泛应用于自动化, AGV, 机器人, 纺织, 印刷, 包装, 医疗器械, 物流, 通信, 家电, 汽车等行业, 远销美国, 德国, 瑞士, 意大利, 法国等30多个国家和地区。

公司技术力量雄厚, 生产工艺成熟, 检验设备齐全。拥有优良的品质保证体系及服务体系, 我们已获得德国TUV认证的ISO9001质量管理体系证书、IATF16949质量管理体系证书以及ISO14001环境管理体系证书, 所有产品获得CE认证, 并符合欧盟RoHS要求, 部分获得UL认证。

公司秉承以质量至上, 创新和社会责任为公司发展理念, 持续为全球客户提供专业化的控制电机制造和研发服务。



Changzhou Fulling Motor Co., Ltd was established in year 2001 as a joint venture of Germany - Swiss - China. We are a professional motor manufacturer in Changzhou city, China. Our Company offers four major series of products: Hybrid stepper motors, DC brushless motors, Servo motors and the motor drivers. Production capacity exceeds more than 6.5 million motors per year. Changzhou Fulling Motor Co., Ltd also has several joint venture companies who specialized in the production of PM stepper motors, and DC gear motors.

We sell nearly 7.5 million different motors to customers worldwide every year. Our products are widely used on industrial automation, AGV, robots, textile, printing, medical equipments, logistics, communication, household appliances and automobile etc. We export our motors to more than 30 countries such as Italy, Germany and United States.

At the core of our development is a professional engineering team that comprises industry experts in the fields of design and application engineering. We provide these talented individuals with access to advanced technology and cutting-edge equipment, ensuring the yield of high-quality products. Our company has successfully passed the quality management system certification for the ISO9001, IATF16949 and ISO14001, which were authorized by the German TUV group. All products are RoHS compliant and CE certified; some are UL approved. Fulling declares no 3TG intentionally added or used in the products or in the production process.

Fulling insists the quality first, innovation and social responsibility as company's concept of development and continues to provide global customers with specialized control motor manufacturing and R&D services.



采用多极多槽方案 Multi-pole and multi-slot solution

- 实现电机的高转矩密度和低齿槽转矩输出,使结构更加紧凑、运行更加平稳
Realize the high torque density, low output cogging torque, more compact structure and more stable operation of the motor.

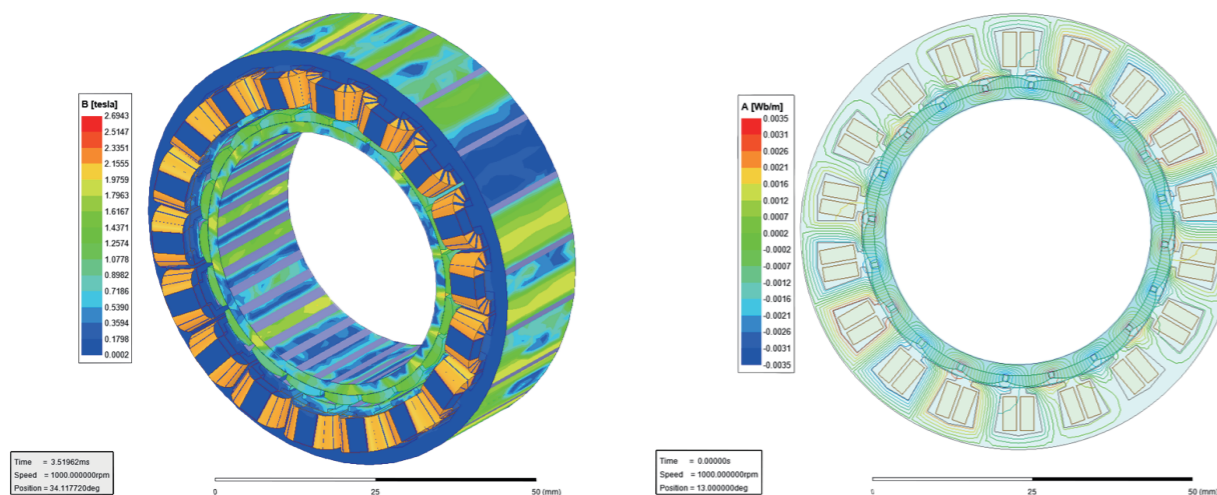

采用真空灌胶工艺 Vacuum glue-filling processing

- 辅助高导热系数灌封胶,使电机散热更加优越,温升更低。
With the aid of high heat conductivity coefficient glue, realize superior heat dissipation and lower temperature rise.



HALL组件和定子组件高度集成化 Highly integrated HALL and stator assembly

- 实现电机的超薄化设计
Realize the ultra-thin design of the motor

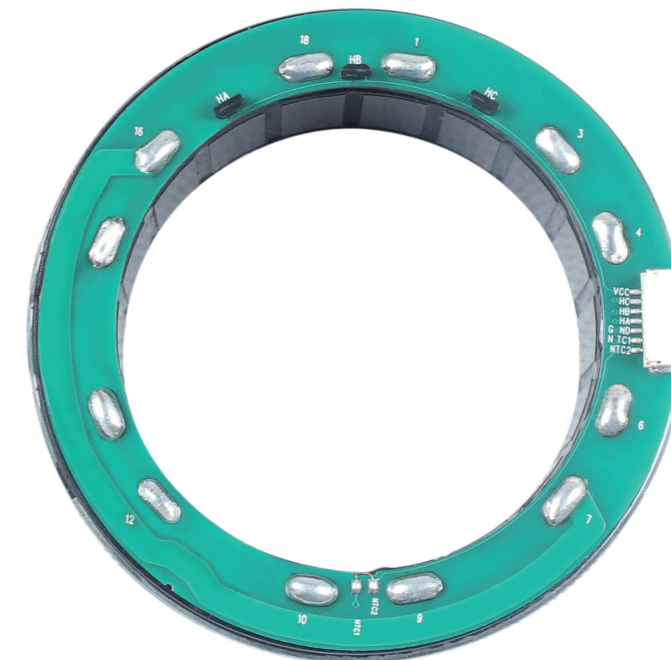

转子特殊化设计 Special design on rotor part

- 最小定转子气隙可达0.25mm,
Min. air gap of stator and rotor up to 0.25 mm

磁钢正弦化设计,
Sinusoidal design on magnetic steel

电机反电动势更加正弦,
More sinusoidal motor Back EMF

实现电机高伺服特性
Realize the motor high servo characteristic



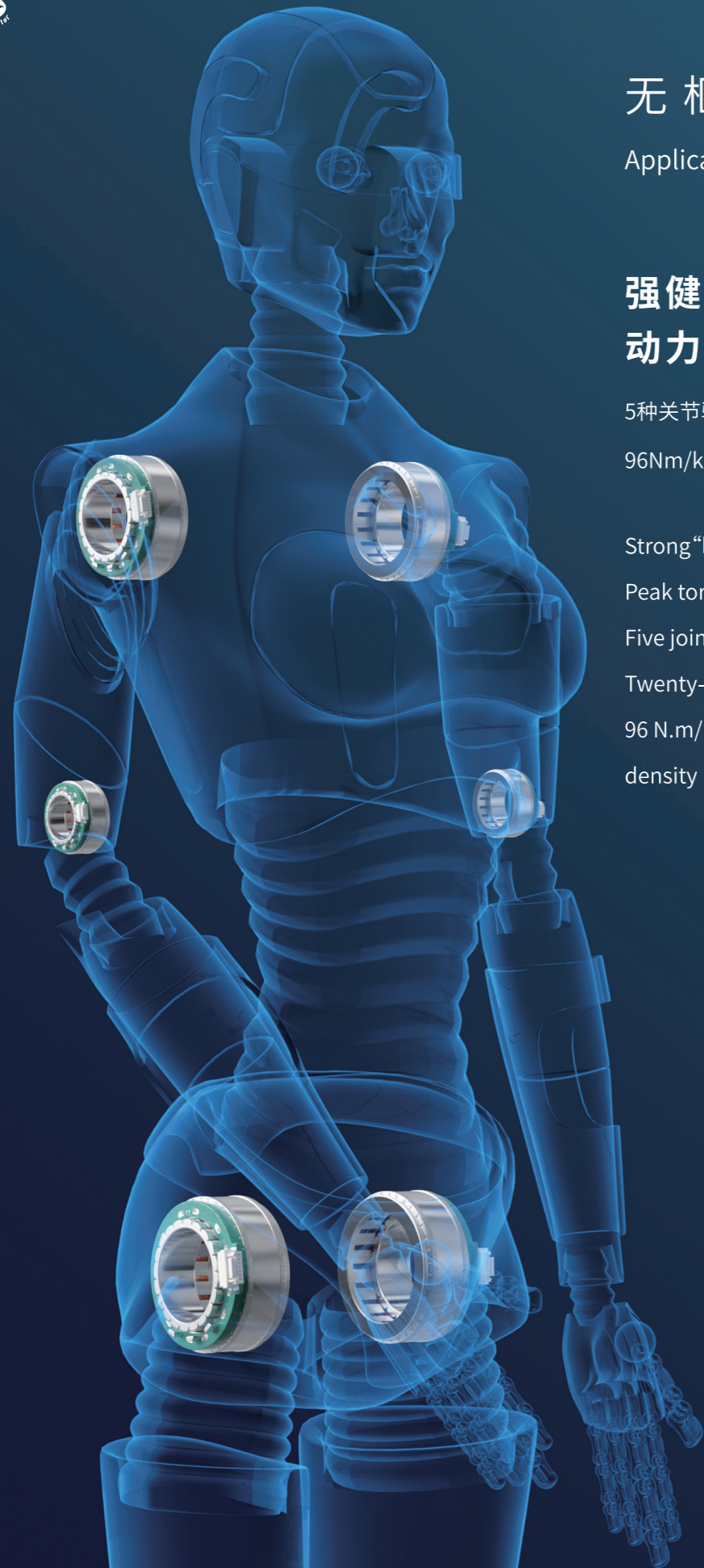

无框电机应用

Application of Fulling frameless motor

强健的【四肢】 动力峰值扭矩400Nm

5种关节驱动, 21个驱动模组

96Nm/kg峰值扭矩密度

Strong "limbs"

Peak torque up to 400 N.m

Five joint drivings

Twenty-one driving module

96 N.m/kg peak torque
density



无框电机在协作机器人、人型机器人等领域得到广泛的应用

Frameless motor is widely used in collaborative robots, humanoid robot, etc.

• 无框电机型号编号规则 (Type Numbering Rules For Frameless Motors)

电动机型号由下列八部分组成，并按下列顺序排列。例下：

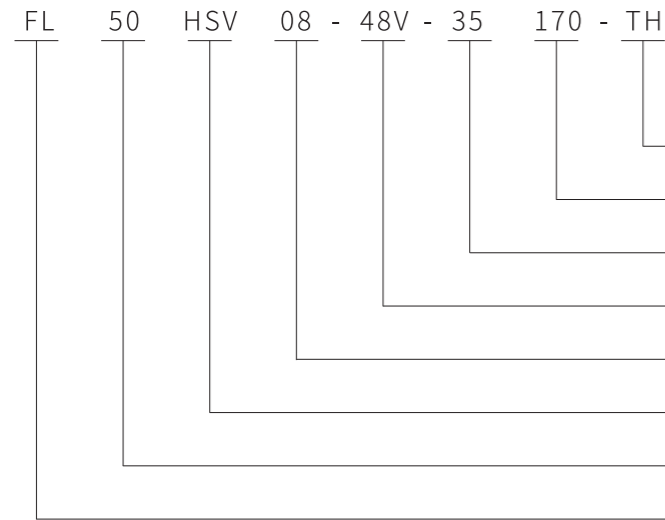

HALL和热敏选配: TH代表有热敏、HALL
 Option for HALL and thermistor: "TH" refer to both thermistor and HALL
 T代表只有热敏, H代表只有HALL
 "T" refer to thermistor only "H" refer to HALL only
 额定功率: 两位及以上数值
 Rated power: Double or more-digit value
 额定转速: 35*100=3500
 Rated speed: 35*100=3500...
 额定电压: 24V, 48V.....
 Rated voltage: 24V, 48V...
 铁芯高度: 8.6mm, 15mm.....
 Lamination height: 8.6mm, 15mm...
 超薄系列: HSV, 伺服系列: MSV
 Ultra thin series: HSV Servo series: MSV
 机座号: 50mm, 69mm, 85mm.....
 Frame size: 50mm, 69mm, 85mm
 公司名称代号: Fulling

• 目录 (Directory)

HSV-超薄系列
Ultra thin series

MSV-伺服系列
Servo series

25HSV	07
38HSV	09
43HSV	11
50HSV	13
60HSV	15
70HSV	17
85HSV	19
102HSV	21
115HSV	23

52MSV	25
60MSV	27
77MSV	29
96MSV	31
122MSV	33

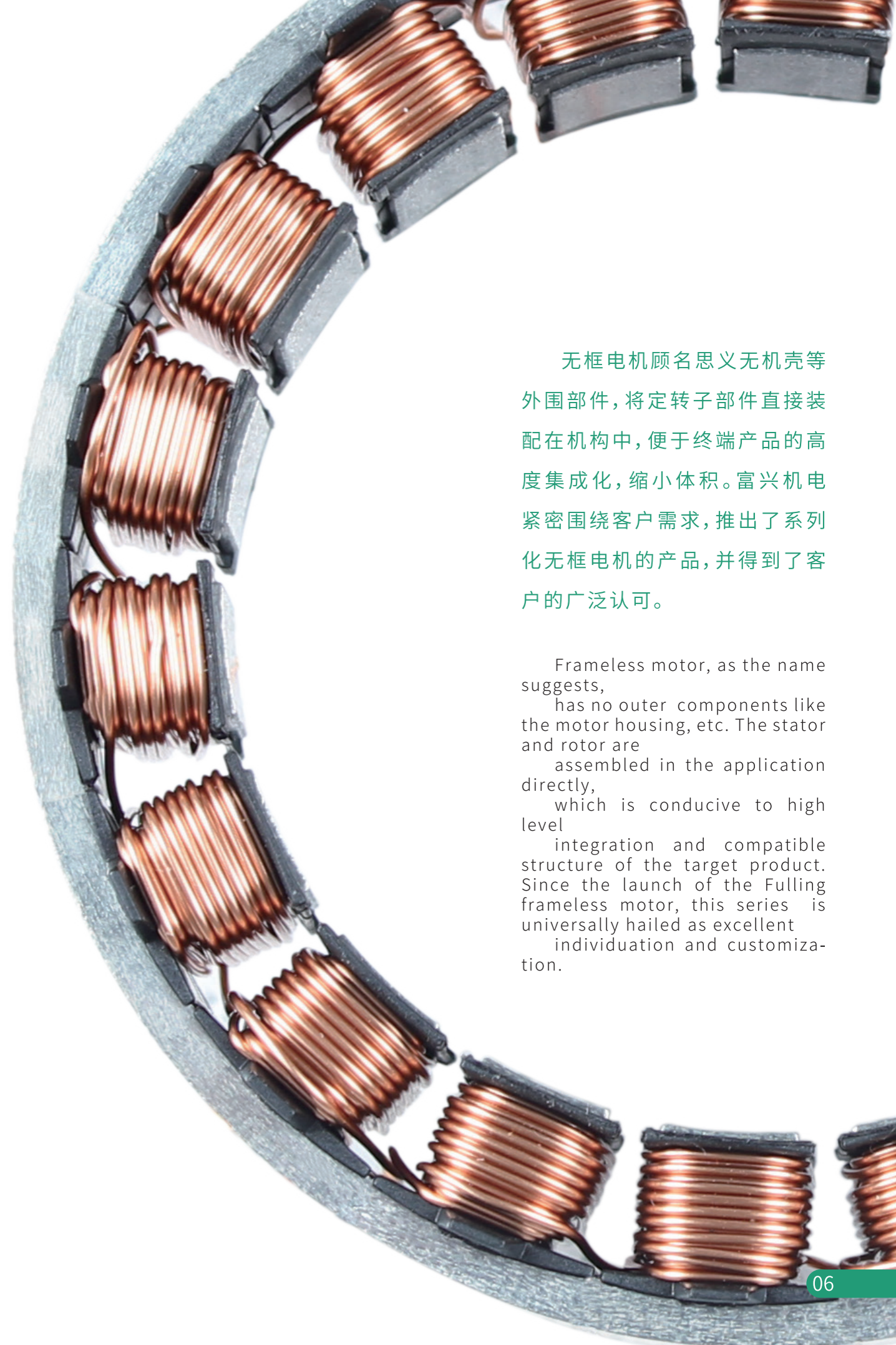

无框电机顾名思义无机壳等外围部件，将定转子部件直接装配在机构中，便于终端产品的高度集成化，缩小体积。富兴机电紧密围绕客户需求，推出了系列化无框电机的产品，并得到了客户的广泛认可。

Frameless motor, as the name suggests, has no outer components like the motor housing, etc. The stator and rotor are assembled in the application directly, which is conducive to high level integration and compatible structure of the target product. Since the launch of the Fulling frameless motor, this series is universally hailed as excellent individuation and customization.

● 机械尺寸 (Dimensions)

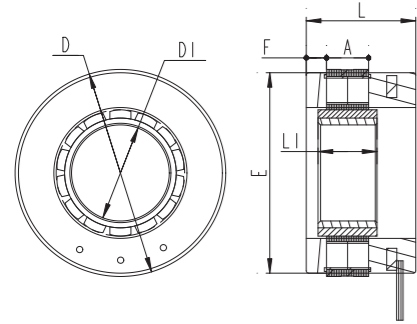

项目 (Items)	FL25HSV05	FL25HSV09	公差 (Tolerance)
定子外径D	25mm	25mm	±0.016(js8)
定子长度L	13mm	17.2mm	0/-1
转子内径D1	11.6mm	11.6mm	(+0.018/0)H7
转子长度L1	7mm	11mm	+0.1/0
灌胶面外圆E	24.2mm	24.2mm	0/-0.2
灌胶面高度F	2.4mm	2.4mm	±0.1
定子铁芯高度A	5mm	9.2mm	+0.2/-0.1



选件 Options



接插件

● 特性概要 (General Specifications)

绕组连接方式 (Winding Type)	星形 (Star connection)
介电强度 (Dielectric Strength)	600VAC/1S.2mA
绝缘电阻 (Insulation Resistance)	100MΩ, 500VDC
环境温度 (Ambient Temperature)	-20°C ~ +50°C
绝缘等级 (Insulation Class)	ClassF

● 接线说明 (Electric Connection)

引出线颜色 (Color)	引出线型号 (Type)	功能 (Functions)
黄色 (Yellow)	ARF250	U相 (Phase U)
红色 (Red)	0.35mm ²	V相 (Phase V)
黑色 (Black)	AWG22	W相 (Phase W)

● 电性能 (Electrical Specifications)

	单位 (Unit)	FL25HSV05-24V-10025	FL25HSV09-24V-10050
极数 (Number of poles)		14	14
相数 (Number of phases)		3	3
额定电压 (Rated voltage)	VDC	24	24
额定转矩 (Rated torque)	mN.m	32	63
额定电流 (Rated current)	A	1.5	3
额定速度 (Rated speed)	RPM	10000	10000
额定功率 (Rated power)	W	33	65
最大转速 (Maximum speed)	RPM	13000	13000
峰值扭矩 (Peak torque)	mN.m	105	204
峰值电流 (Peak current)	A	5	9.8
线电阻 (Line to line resistance)	ohms@20°C	1.7	0.77
线电感 (Line to line inductance)	mH	0.6	0.28
转矩常数 (Torque constant)	mNm/A	21.5	21.5
反电势 (Back EMF)	Vrms/KRPM	1.3	1.3
重量 (Weight)	g	18	28.5
电气时间常数 (Electrical time constant)	ms	0.35	0.36

● 性能曲线 (Performance Curve)

FL25HSV05-24V-10025

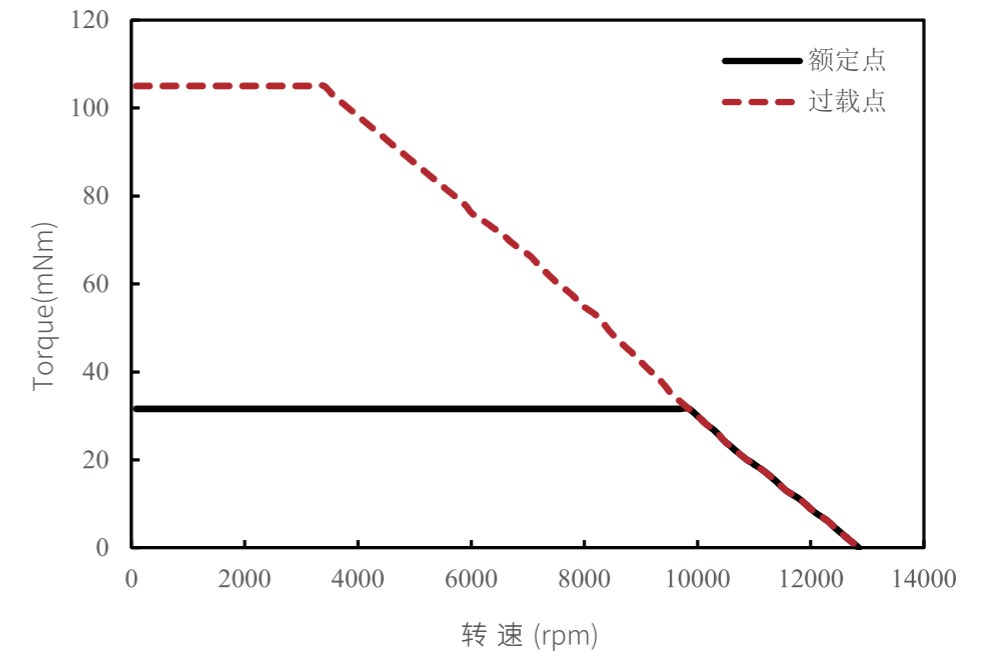

FL25HSV09-24V-10050

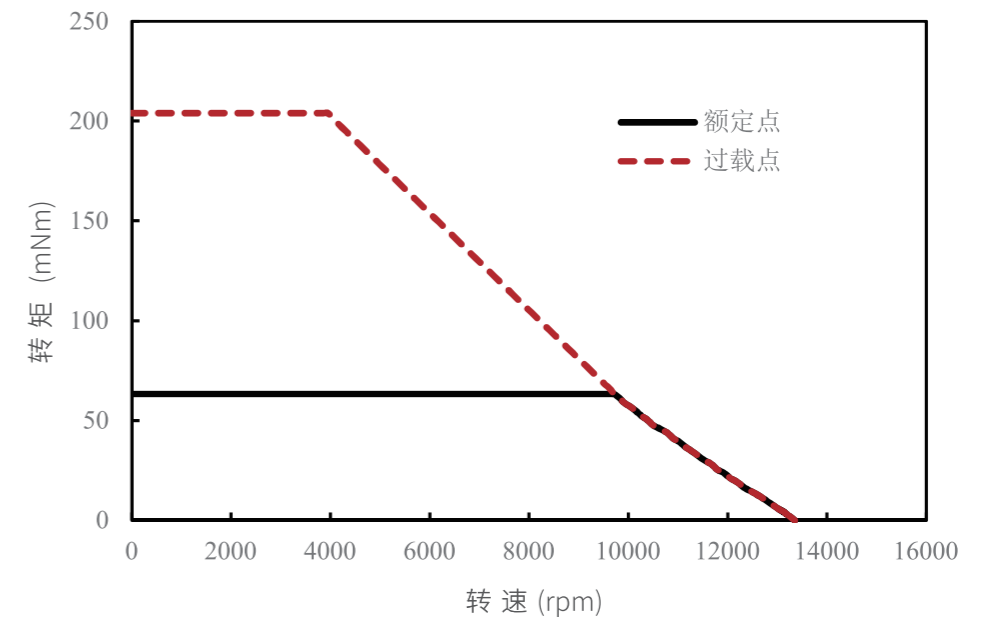

● 机械尺寸

(Dimensions)

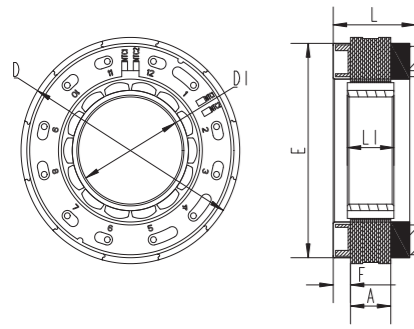

项目 (Items)	FL38HSV07	FL38HSV14	公差 (Tolerance)
定子外径D	38mm	38mm	±0.031(js9)
定子长度L	14.8mm	21.8mm	±1
转子内径D1	18mm	18mm	(+0.027/0)H8
转子长度L1	8.1mm	16.1mm	±0.2
灌胶面外圆E	36mm	36mm	/
灌胶面高度F	3mm	3mm	±0.5
定子铁芯高度A	7mm	14mm	/

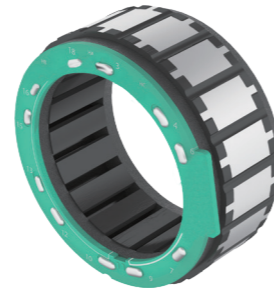

选件 Options



接插件

● 特性概要

(General Specifications)

绕组连接方式 (Winding Type)	星形 (Star connection)
介电强度 (Dielectric Strength)	600VAC/1S.2mA
绝缘电阻 (Insulation Resistance)	100MΩ, 500VDC
环境温度 (Ambient Temperature)	-20°C ~ +50°C
绝缘等级 (Insulation Class)	Class B

● 接线说明

(Electric Connection)

引出线颜色 Color	引出线型号 Type	功能 Functions
蓝色 (BLU)	UL1061 AWG26	NTC
红色 (RED)		NTC
黄色 (Yellow)	AGR-TR AWG 22	U相 (Phase U)
红色 (Red)		V相 (Phase V)
黑色 (Black)		W相 (Phase W)

● 电性能

(Electrical Specifications)

	单位 (Unit)	FL38HSV07-24V-8085	FL38HSV14-48V-50120
极数 (Number of poles)		14	14
相数 (Number of phases)		3	3
额定电压 (Rated voltage)	VDC	24	48
额定转矩 (Rated torque)	N.m	0.1	0.23
额定电流 (Rated current)	A	4.5	3.6
额定速度 (Rated speed)	RPM	8000	5000
额定功率 (Rated power)	W	83	120
最大转速 (Maximum speed)	RPM	11000	7500
峰值转矩 (Peak torque)	N.m	0.3	0.69
峰值电流 (Peak current)	A	13.5	10.8
线电阻 (Line to line resistance)	ohms@20°C	0.365	1.24
线电感 (Line to line inductance)	mH	0.32	1.3
转矩常数 (Torque constant)	Nm/A	0.0255	0.074
反电势 (Back EMF)	Vrms/KRPM	1.54	4.5
重量 (Weight)	g	57.2	95
电气时间常数 (Electrical time constant)	ms	0.87	1.05

● 性能曲线

(Performance Curve)

FL38HSV07-24V-8085

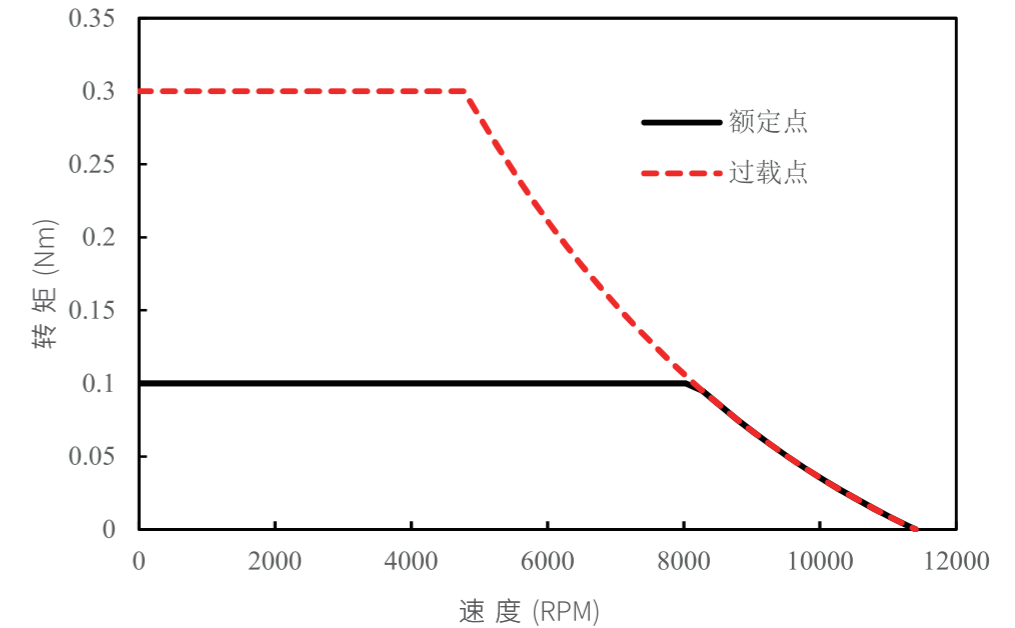

FL38HSV14-48V-50120

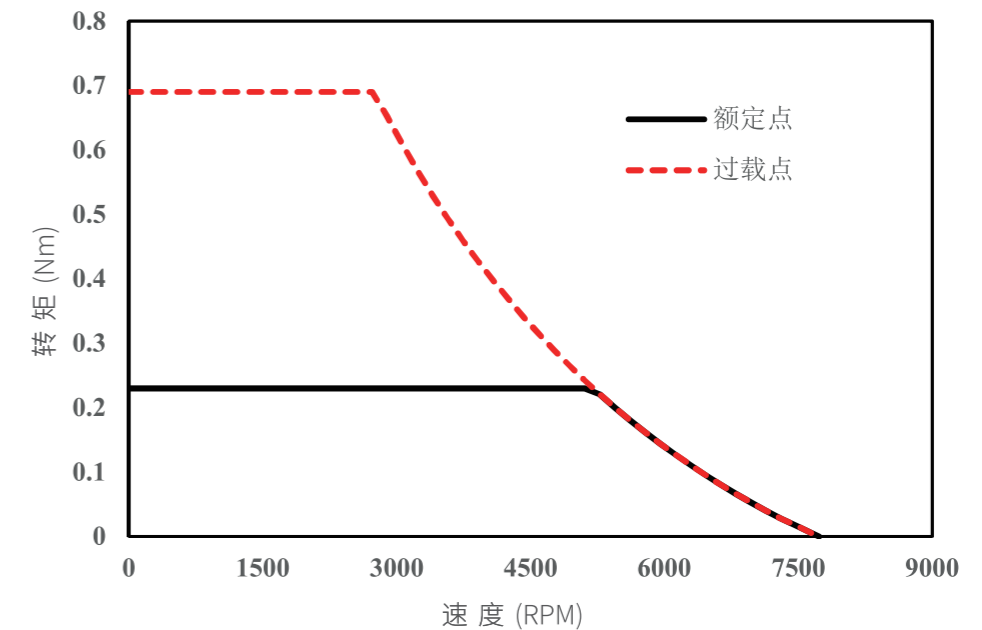

● 机械尺寸

(Dimensions)

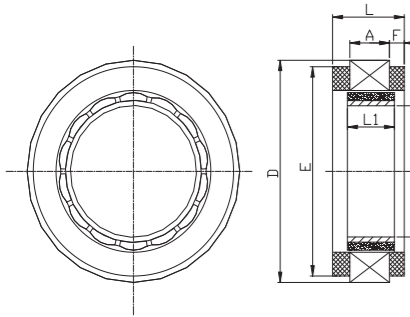

项目(Items)	FL43HSV08	公差(Tolerance)
定子外径D	43mm	±0.031(js9)
定子长度L	15.5mm	±1
转子内径D1	30mm	(+0.033/0)H8
转子长度L1	9.5mm	±0.2
灌胶面外圆E	40.5mm	/
灌胶面高度F	3.0mm	±0.3
定子铁芯高度A	8.0mm	/

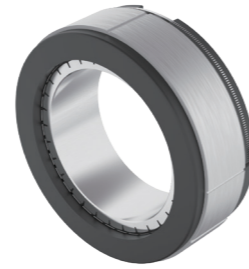

选件 Options



接插件

● 特性概要

(General Specifications)

绕组连接方式 (Winding Type)	星形 (Star connection)
介电强度 (Dielectric Strength)	650VAC/1S.2mA
绝缘电阻 (Insulation Resistance)	100MΩ, 500VDC
环境温度 (Ambient Temperature)	-20°C ~ +50°C
绝缘等级 (Insulation Class)	Class B

● 接线说明

(Electric Connection)

引出线颜色 Color	引出线型号 Type	功能 Functions
黄色 (Yellow)	UL1332 AWG24	U相 (Phase U)
红色 (Red)		V相 (Phase V)
黑色 (Black)		W相 (Phase W)

● 电性能

(Electrical Specifications)

	单位 (Unit)	FL43HSV08-36V-5078
极数 (Number of poles)		14
相数 (Number of phases)		3
额定电压 (Rated voltage)	VDC	36
额定转矩 (Rated torque)	N.m	0.15
额定电流 (Rated current)	A	3.0
额定速度 (Rated speed)	RPM	5000
额定功率 (Rated power)	W	78.5
最大转速 (Maximum speed)	RPM	7600
峰值扭矩 (Peak torque)	N.m	0.45
峰值电流 (Peak current)	A	9.0
线电阻 (Line to line resistance)	ohms@20°C	1.5
线电感 (Line to line inductance)	mH	1.0
转矩常数 (Torque constant)	Nm/A	0.05
反电势 (Back EMF)	Vrms/KRPM	3.7
重量 (Weight)	g	85
电气时间常数 (Electrical time constant)	ms	0.667

● 性能曲线

(Performance Curve)

FL43HSV08-36V-5078

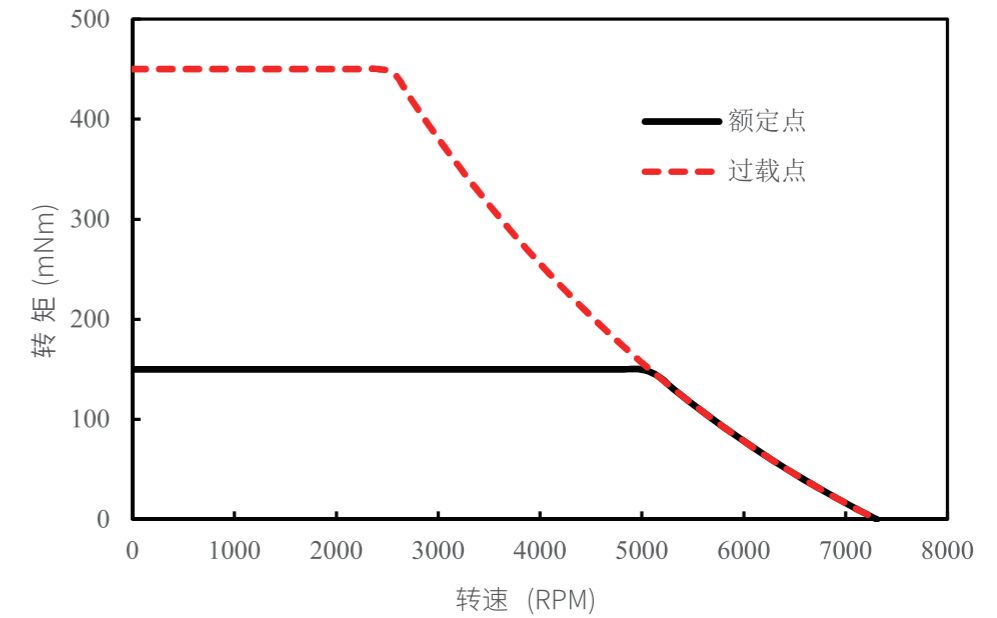

● 机械尺寸

(Dimensions)

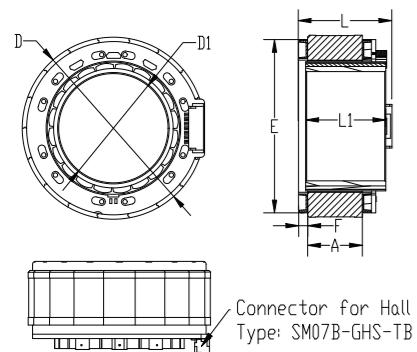

项目 (Items)	FL50HSV08	FL50HSV15	公差 (Tolerance)
定子外径D	50mm	50mm	±0.031(js9)
定子长度L	20mm	26mm	±1
转子内径D1	30mm	30mm	(+0.033/0)H8
转子长度L1	16mm	22mm	±0.2
灌胶面外圆E	47.6mm	47.6mm	±0.2
灌胶面高度F	2.5mm	2.5mm	±0.3
定子铁芯高度A	8.6mm	15mm	\



选件 Options



接插件

● 特性概要

(General Specifications)

绕组连接方式 (Winding Type)	星形 (Star connection)
霍尔分布角度 (Hall Effect Angle)	120度电角度 (Electrical Angle of 120 degree)
介电强度 (Dielectric Strength)	1000VAC/1S.2mA
绝缘电阻 (Insulation Resistance)	100MΩ, 500VDC
使用环境 (Operation Ambient)	-20°C ~ +50°C
绝缘等级 (Insulation Class)	Class B

● 接线说明

(Electric Connection)

引出线颜色 Color	引出线型号 Type	功能 Functions
PIN1	Connector for Hall is optional Type: SM07B-GHS-TB	热敏 (NTC2)
PIN2		热敏 (NTC1)
PIN3		霍尔电源负 (GND)
PIN4		霍尔 A (Ha)
PIN5		霍尔 B (Hb)
PIN6		霍尔 C (Hc)
PIN7		霍尔电源正 (Vcc)
黄色 (Yellow)	UL1332 AWG20	U相 (Phase U)
红色 (Red)		V相 (Phase V)
黑色 (Black)		W相 (Phase W)

● 电性能

(Electrical Specifications)

	单位 (Unit)	FL50HSV08-48V-50170-TH	FL50HSV15-48V-35183-TH
极数 (Number of poles)		20	20
相数 (Number of phases)		3	3
额定电压 (Rated voltage)	VDC	48	48
额定转矩 (Rated torque)	N.m	0.3	0.5
额定电流 (Rated current)	A	3.6	4.8
额定速度 (Rated speed)	RPM	5000	3500
额定功率 (Rated power)	W	157	183
最大转速 (Maximum speed)	RPM	6200	4800
峰值转矩 (Peak torque)	N.m	0.96	1.5
峰值电流 (Peak current)	A	11.6	14.5
线电阻 (Line to line resistance)	ohms@20°C	0.93	0.77
线电感 (Line to line inductance)	mH	0.45	0.38
转矩常数 (Torque constant)	Nm/A	0.089	0.117
反电势 (Back EMF)	Vrms/KRPM	5.4	7.1
重量 (Weight)	g	96	147
电气时间常数 (Electrical time constant)	ms	0.48	0.49

● 性能曲线

(Performance Curve)

FL50HSV08-48V-50170-TH

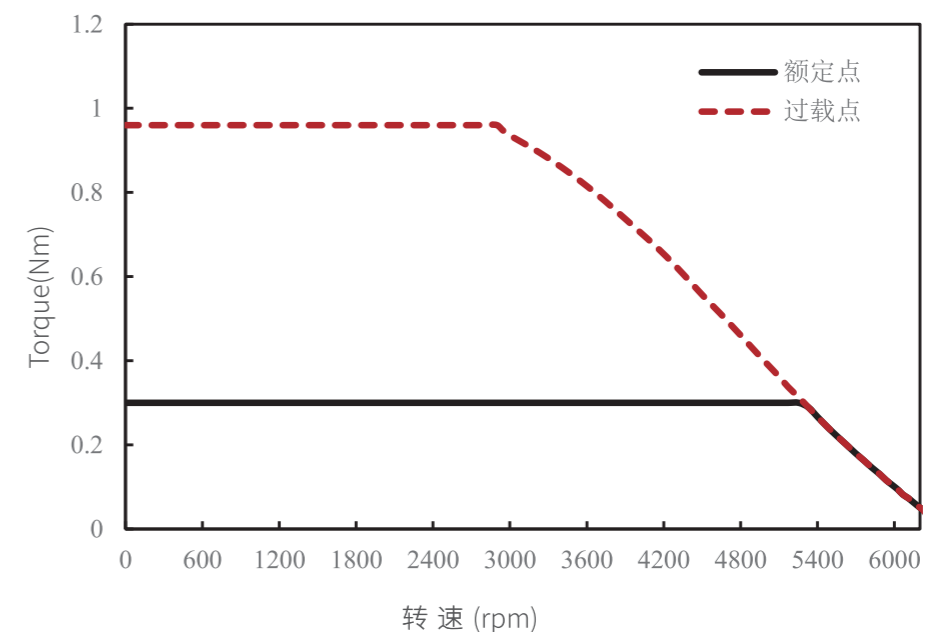

FL50HSV15-48V-35183-TH

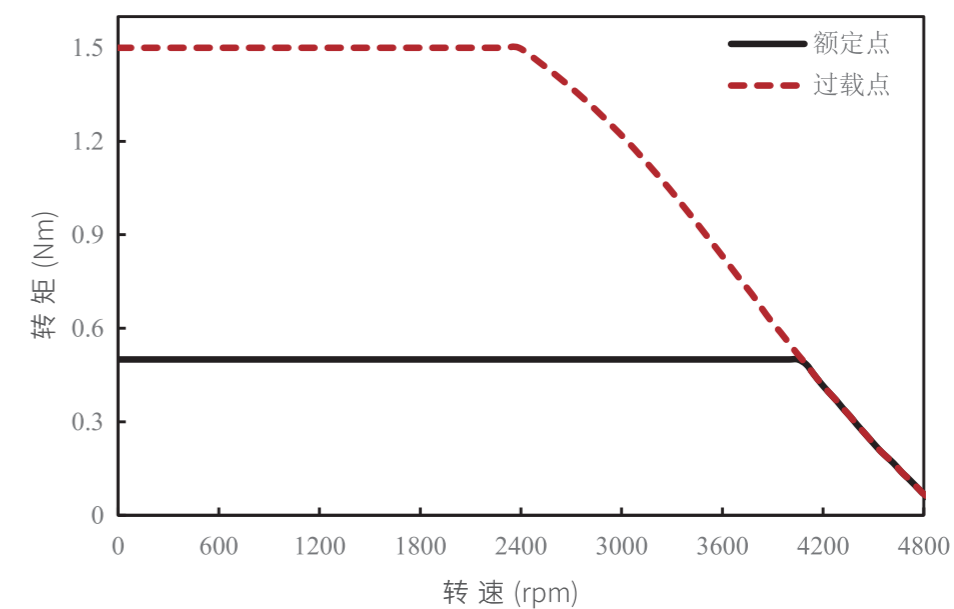

● 机械尺寸

(Dimensions)

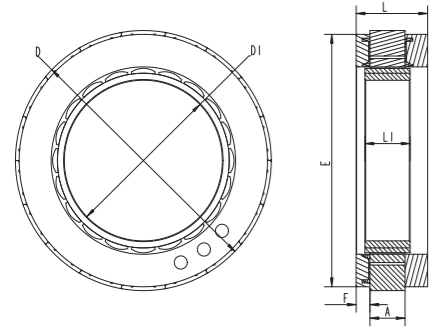

项目(Items)	FL60HSV12	公差(Tolerance)
定子外径D	60mm	±0.03(js9)
定子长度L	22.2mm	/
转子内径D1	39.2mm	(+0.039/0)H8
转子长度L1	16mm	±0.2
灌胶面外圆E	58mm	/
灌胶面高度F	3.7mm	±0.5
定子铁芯高度A	12mm	/

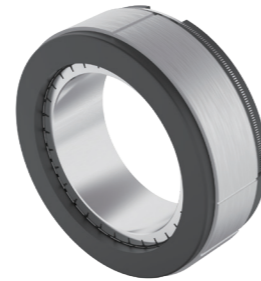

选件 Options



接插件

● 特性概要

(General Specifications)

绕组连接方式 (Winding Type)	星形 (Star connection)
介电强度 (Dielectric Strength)	1000VAC/1S.2mA
绝缘电阻 (Insulation Resistance)	100MΩ, 500VDC
环境温度 (Ambient Temperature)	-20°C ~ +50°C
绝缘等级 (Insulation Class)	Class B

● 接线说明

(Electric Connection)

引出线颜色 Color	引出线型号 Type	功能 Functions
黄色 (Yellow)	UL1332 AWG16	U相 (Phase U)
红色 (Red)		V相 (Phase V)
黑色 (Black)		W相 (Phase W)

● 电性能

(Electrical Specifications)

	单位 (Unit)	FL60HSV12-48V-40188
极数 (Number of poles)		20
相数 (Number of phases)		3
额定电压 (Rated voltage)	VDC	48
额定转矩 (Rated torque)	N.m	0.45
额定电流 (Rated current)	A	5.0
额定速度 (Rated speed)	RPM	4000
额定功率 (Rated power)	W	188
最大转速 (Maximum speed)	RPM	5200
峰值扭矩 (Peak torque)	N.m	1.35
峰值电流 (Peak current)	A	15
线电阻 (Line to line resistance)	ohms@20°C	0.58
线电感 (Line to line inductance)	mH	0.47
转矩常数 (Torque constant)	Nm/A	0.102
反电势 (Back EMF)	Vrms/KRPM	6.15
重量 (Weight)	g	160
电气时间常数 (Electrical time constant)	ms	0.81

● 性能曲线

(Performance Curve)

FL60HSV12-48V-40188

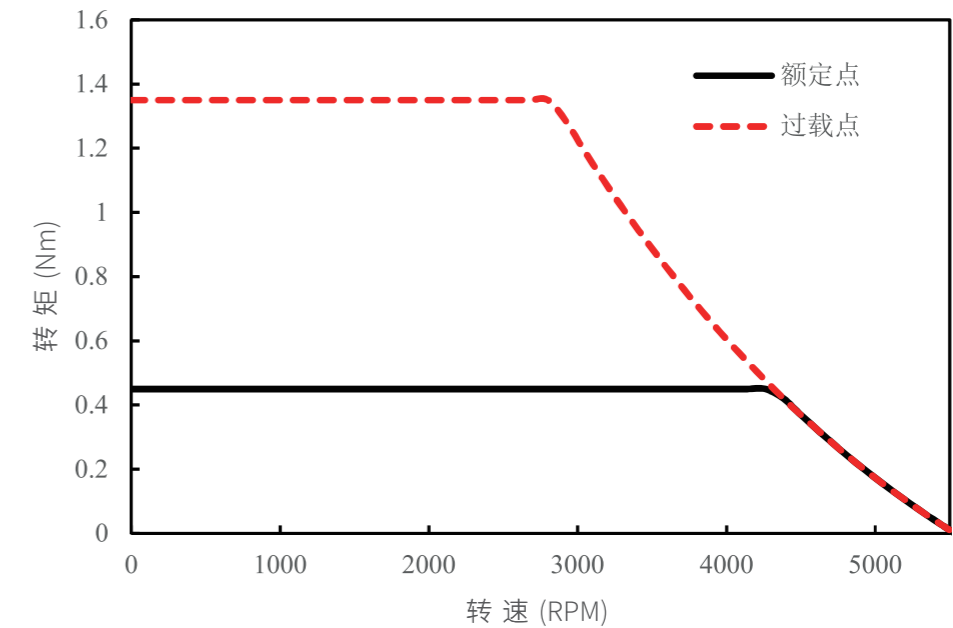

● 机械尺寸

(Dimensions)

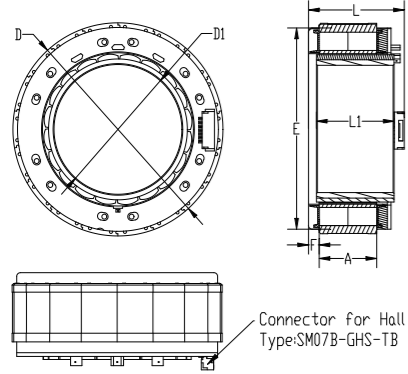

项目 (Items)	FL70HSV10	FL70HSV19	公差 (Tolerance)
定子外径D	69mm	69mm	±0.037(js9)
定子长度L	23.5mm	32mm	±1
转子内径D1	42mm	42mm	+0.039/0(H8)
转子长度L1	18mm	27.5mm	±0.2
灌胶面外圆E	66mm	66mm	±0.2
灌胶面高度F	3.5mm	3.5mm	±0.3
定子铁芯高度A	10mm	18.9mm	\

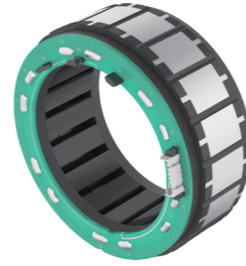

选件 Options



接插件

● 特性概要

(General Specifications)

绕组连接方式 (Winding Type)	星形 (Star connection)
霍尔分布角度 (Hall Effect Angle)	120度电角度 (Electrical Angle of 120 degree)
介电强度 (Dielectric Strength)	1000VAC/1S
绝缘电阻 (Insulation Resistance)	100MΩ, 500VDC
使用环境 (Operation Ambient)	-20°C ~ +50°C
绝缘等级 (Insulation Class)	Class B

● 接线说明

(Electric Connection)

引出线颜色 Color	引出线型号 Type	功能 Functions
PIN1	Connector for Hall is optional Type: SM07B-GHS-TB	热敏 (NTC2)
PIN2		热敏 (NTC1)
PIN3		霍尔电源负 (GND)
PIN4		霍尔 A (Ha)
PIN5		霍尔 B (Hb)
PIN6		霍尔 C (Hc)
PIN7		霍尔电源正 (Vcc)
黄色 (Yellow)	UL1332 AWG18	U相 (Phase U)
红色 (Red)		V相 (Phase V)
黑色 (Black)		W相 (Phase W)

● 电性能

(Electrical Specifications)

	单位 (Unit)	FL70HSV10-48V-36250-TH	FL70HSV19-48V-35366-TH
极数 (Number of poles)		20	20
相数 (Number of phases)		3	3
额定电压 (Rated voltage)	VDC	48	48
额定转矩 (Rated torque)	N.m	0.55	1.0
额定电流 (Rated current)	A	5.1	9.2
额定速度 (Rated speed)	RPM	3650	3500
额定功率 (Rated power)	W	210	366
最大转速 (Maximum speed)	RPM	4750	4500
峰值转矩 (Peak torque)	N.m	1.65	3.0
峰值电流 (Peak current)	A	15.5	28
线电阻 (Line to line resistance)	ohms@20°C	0.38	0.19
线电感 (Line to line inductance)	mH	0.33	0.18
转矩常数 (Torque constant)	Nm/A	0.118	0.12
反电势 (Back EMF)	Vrms/KRPM	7.14	7.4
重量 (Weight)	g	210	315
电气时间常数 (Electrical time constant)	ms	0.87	0.95

● 性能曲线

(Performance Curve)

FL70HSV10-48V-36250-TH

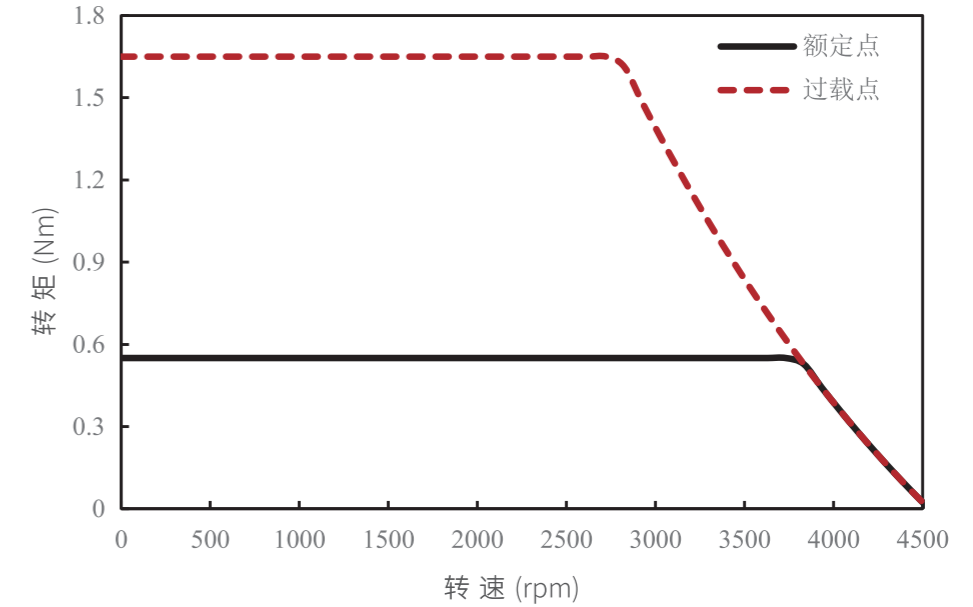

FL70HSV19-48V-35366-TH

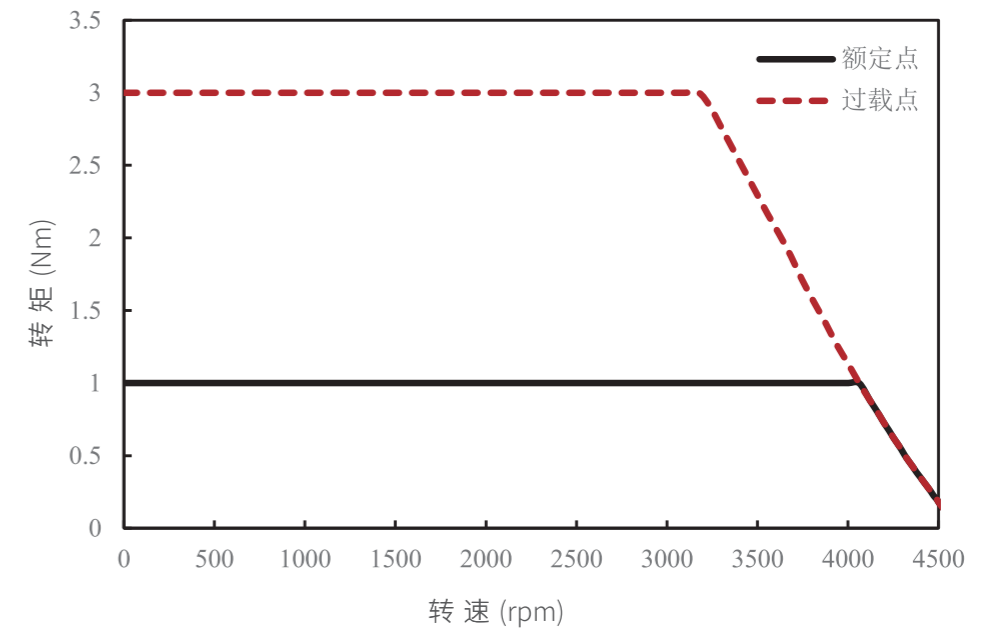

● 机械尺寸

(Dimensions)

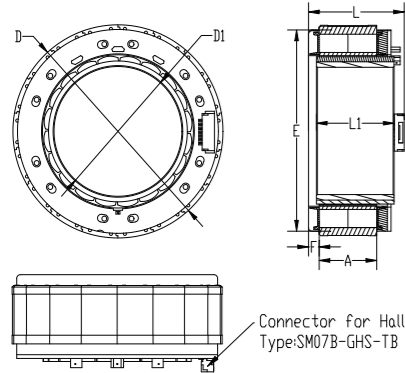

项目 (Items)	FL85HSV13	FL85HSV23	公差 (Tolerance)
定子外径D	85mm	85mm	±0.043(js9)
定子长度L	27.5mm	36mm	±1
转子内径D1	52mm	52mm	+0.046/0(H8)
转子长度L1	22.5mm	34mm	±0.2
灌胶面外圆E	81mm	81mm	±0.2
灌胶面高度F	4.2mm	4.2mm	±0.3
定子铁芯高度A	13mm	23mm	\

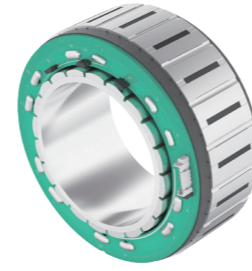

选件 Options



接插件

● 特性概要

(General Specifications)

绕组连接方式 (Winding Type)	星形 (Star connection)
霍尔分布角度 (Hall Effect Angle)	120度电角度 (Electrical Angle of 120 degree)
介电强度 (Dielectric Strength)	1000VAC/1S
绝缘电阻 (Insulation Resistance)	100MΩ, 500VDC
使用环境 (Operation Ambient)	-20°C ~ +50°C
绝缘等级 (Insulation Class)	Class B

● 接线说明

(Electric Connection)

引出线颜色 Color	引出线型号 Type	功能 Functions
PIN1	Connector for Hall is optional Type: SM07B-GHS-TB	热敏 (NTC2)
PIN2		热敏 (NTC1)
PIN3		霍尔电源负 (GND)
PIN4		霍尔 A (Ha)
PIN5		霍尔 B (Hb)
PIN6		霍尔 C (Hc)
PIN7		霍尔电源正 (Vcc)
黄色 (Yellow)	UL1332 AWG16	U相 (Phase U)
红色 (Red)		V相 (Phase V)
黑色 (Black)		W相 (Phase W)

● 电性能

(Electrical Specifications)

	单位 (Unit)	FL85HSV13-48V-29400-TH	FL85HSV23-48V-350730-TH
极数 (Number of poles)		20	20
相数 (Number of phases)		3	3
额定电压 (Rated voltage)	VDC	48	48
额定转矩 (Rated torque)	N.m	1.2	2.0
额定电流 (Rated current)	A	8.6	15
额定速度 (Rated speed)	RPM	2950	3500
额定功率 (Rated power)	W	370	732
最大转速 (Maximum speed)	RPM	3700	4000
峰值转矩 (Peak torque)	N.m	3.6	6.0
峰值电流 (Peak current)	A	25.8	45
线电阻 (Line to line resistance)	ohms@20°C	0.23	0.09
线电感 (Line to line inductance)	mH	0.3	0.13
转矩常数 (Torque constant)	Nm/A	0.15	0.14
反电势 (Back EMF)	Vrms/KRPM	9	8.3
重量 (Weight)	g	386	597
电气时间常数 (Electrical time constant)	ms	1.3	1.44

● 性能曲线

(Performance Curve)

FL85HSV13-48V-29400-TH

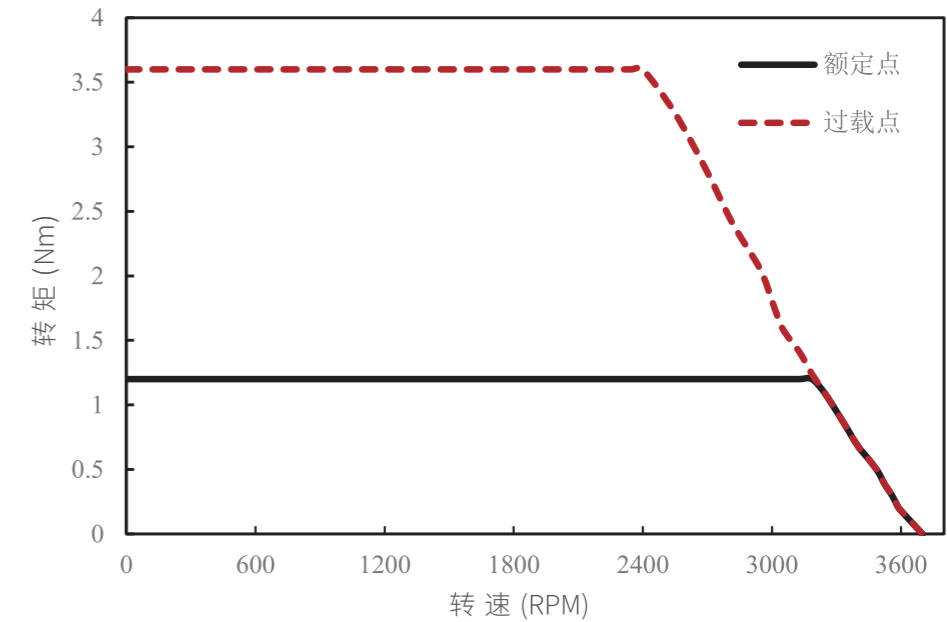

FL85HSV23-48V-350730-TH

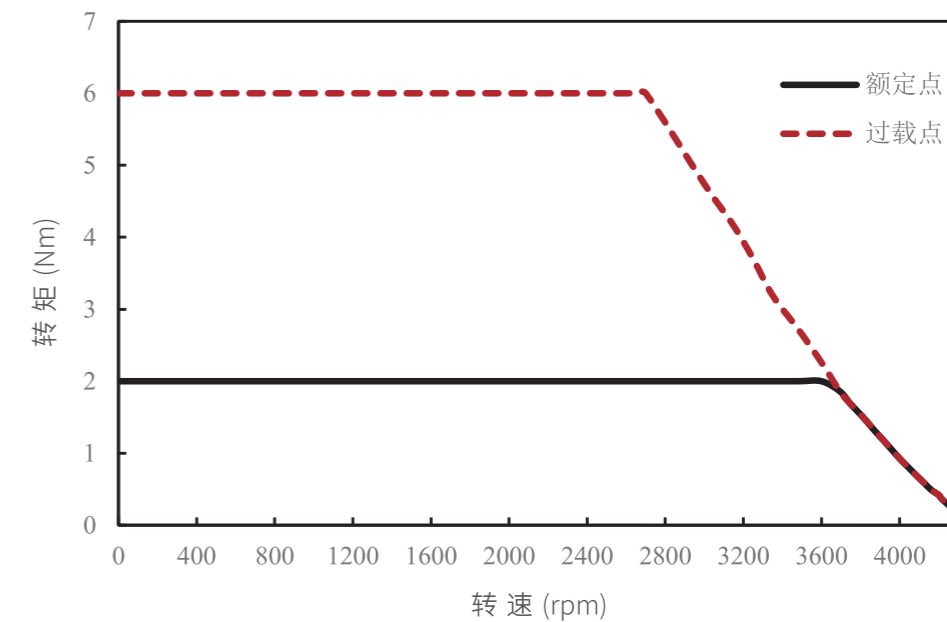

● 机械尺寸

(Dimensions)

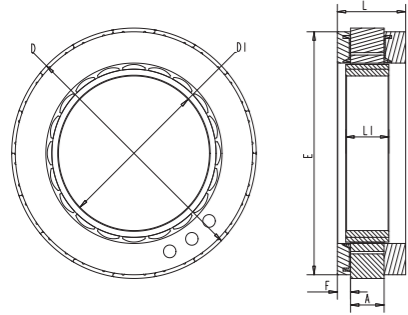

项目(Items)	FL102HSV14	公差(Tolerance)
定子外径D	102mm	±0.043(js9)
定子长度L	23mm	±1
转子内径D1	63mm	(+0.027/0)H8
转子长度L1	18mm	±0.2
灌胶面外圆E	99mm	/
灌胶面高度F	5.5mm	±0.5
定子铁芯高度A	14mm	/

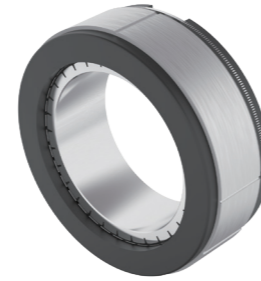

选件 Options



接插件

● 特性概要

(General Specifications)

绕组连接方式 (Winding Type)	星形 (Star connection)
介电强度 (Dielectric Strength)	1000VAC/1S.2mA
绝缘电阻 (Insulation Resistance)	100MΩ, 500VDC
环境温度 (Ambient Temperature)	-20°C ~ +50°C
绝缘等级 (Insulation Class)	Class B

● 接线说明

(Electric Connection)

引出线颜色 Color	引出线型号 Type	功能 Functions
黄色 (Yellow)	UL1332 AWG16	U相 (Phase U)
红色 (Red)		V相 (Phase V)
黑色 (Black)		W相 (Phase W)

● 电性能

(Electrical Specifications)

	单位 (Unit)	FL102HSV14-48V-20530
极数 (Number of poles)		20
相数 (Number of phases)		3
额定电压 (Rated voltage)	VDC	48
额定转矩 (Rated torque)	N.m	2.5
额定电流 (Rated current)	A	15.8
额定速度 (Rated speed)	RPM	2000
额定功率 (Rated power)	W	523
最大转速 (Maximum speed)	RPM	3100
峰值扭矩 (Peak torque)	N.m	7.5
峰值电流 (Peak current)	A	44.4
线电阻 (Line to line resistance)	ohms@20°C	0.154
线电感 (Line to line inductance)	mH	0.54
转矩常数 (Torque constant)	Nm/A	0.184
反电势 (Back EMF)	Vrms/KRPM	11.1
重量 (Weight)	g	608
电气时间常数 (Electrical time constant)	ms	3.51

● 性能曲线

(Performance Curve)

FL102HSV14-48V-20530

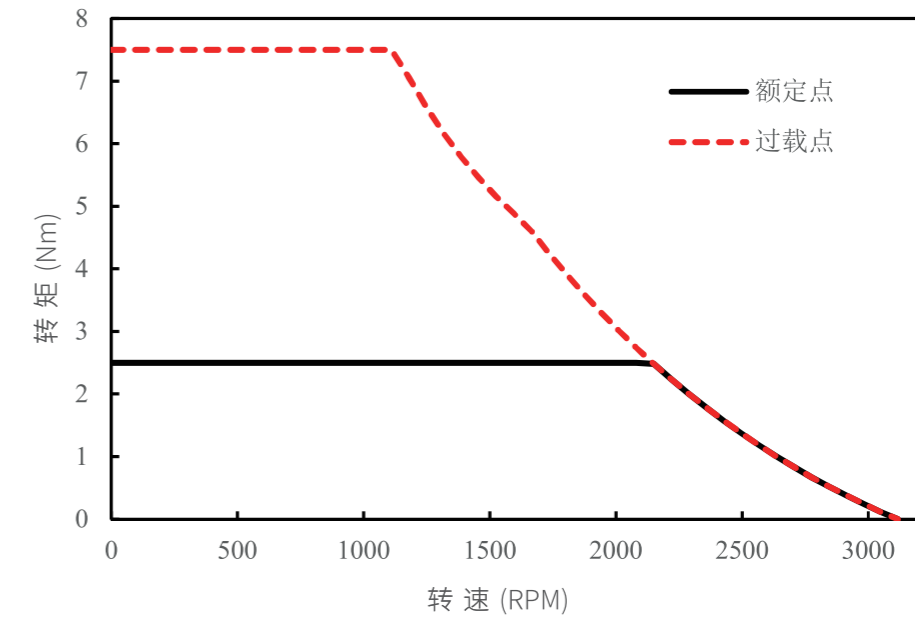

● 机械尺寸

(Dimensions)

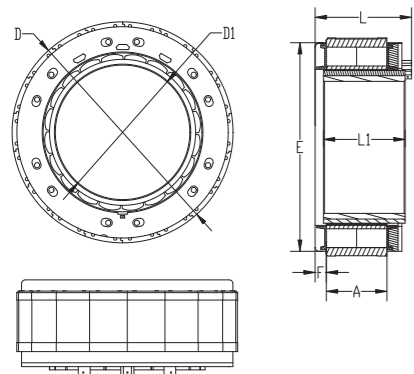

项目 (Items)	FL115HSV25	FL115HSV50	公差 (Tolerance)
定子外径D	115mm	115mm	js9
定子长度L	39mm	68mm	±1
转子内径D1	74mm	74mm	H8
转子长度L1	32.7mm	57.7mm	±0.25
灌胶面外圆E	112mm	112mm	±0.2
灌胶面高度F	5.5mm	5.5mm	±0.3
定子铁芯高度A	25mm	50mm	\

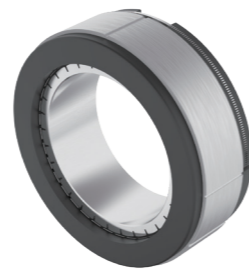

选件 Options



接插件

● 特性概要

(General Specifications)

绕组连接方式 (Winding Type)	星形 (Star connection)
霍尔分布角度 (Hall Effect Angle)	120度电角度 (Electrical Angle of 120 degree)
介电强度 (Dielectric Strength)	1000VAC/1S
绝缘电阻 (Insulation Resistance)	100MΩ, 500VDC
使用环境 (Operation Ambient)	-20°C ~ +50°C
绝缘等级 (Insulation Class)	Class B

● 接线说明

(Electric Connection)

引出线颜色 Color	引出线型号 Type	功能 Functions
红色 (Red)	UL2464 AWG26 Hall is optional	霍尔电源正 (Vcc)
蓝色 (Blue)		霍尔 W (Hw)
绿色 (Green)		霍尔 V (Hv)
白色 (White)		霍尔 U (Hu)
黑色 (Black)	UL1332 AWG18	霍尔电源负 (GND)
黄色 (Yellow)		U相 (Phase U)
红色 (Red)		V相 (Phase V)
黑色 (Black)		W相 (Phase W)

● 电性能

(Electrical Specifications)

	单位 (Unit)	FL115HSV25	FL115HSV50
极数 (Number of poles)		20	20
相数 (Number of phases)		3	3
额定电压 (Rated voltage)	VDC	48	48
额定转矩 (Rated torque)	N.m	3.9	7.8
额定电流 (Rated current)	A	14.7	13
额定速度 (Rated speed)	RPM	1400	620
额定功率 (Rated power)	W	571	617
最大转速 (Maximum speed)	RPM	1900	850
峰值扭矩 (Peak torque)	N.m	11.7	23.4
峰值电流 (Peak current)	A	44.1	39
线电阻 (Line to line resistance)	ohms@20°C	0.16	0.51
线电感 (Line to line inductance)	mH	0.53	0.69
转矩常数 (Torque constant)	Nm/A	0.293	0.662
反电势 (Back EMF)	Vrms/KRPM	17.7	40
重量 (Weight)	g	1110	2200
电气时间常数 (Electrical time constant)	ms	3.31	1.35

● 性能曲线

(Performance Curve)

FL115HSV25-48V-14570-TH

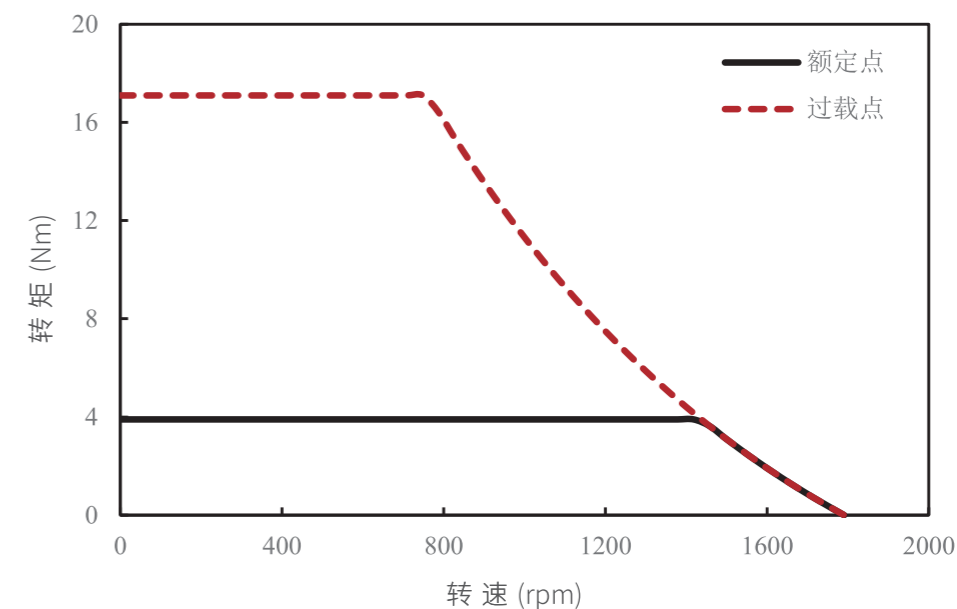

FL115HSV50-48V-06620-TH

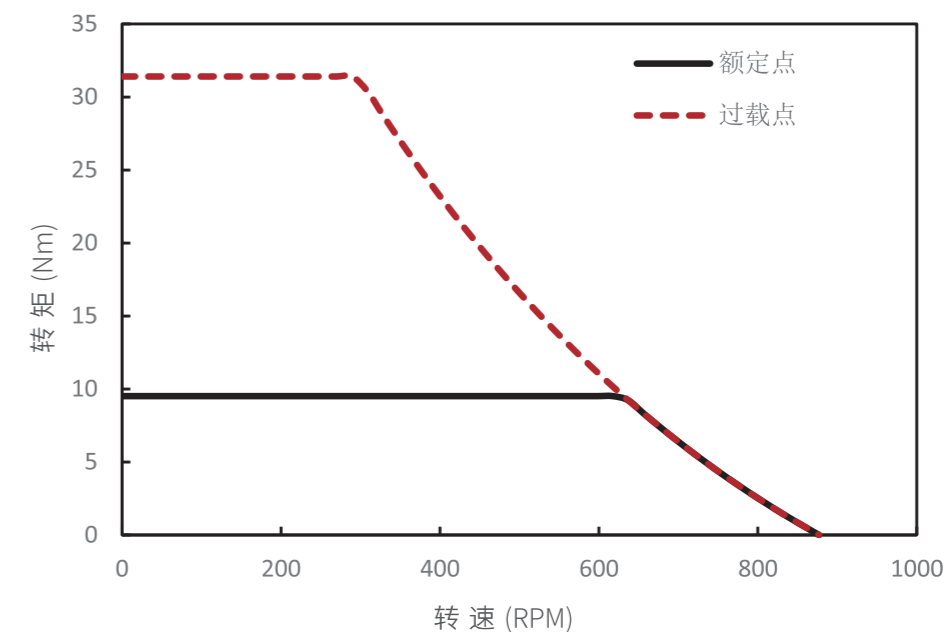

● 机械尺寸

(Dimensions)

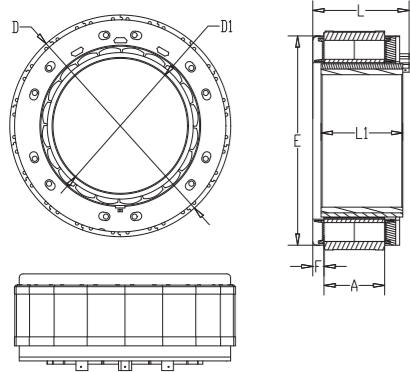

项目(Items)	FL52MSV15	公差(Tolerance)
定子外径D	52mm	js9
定子长度L	26mm	±1
转子内径D1	19mm	H8
转子长度L1	18mm	±0.25
骨架外圆E	50.5mm	±0.2

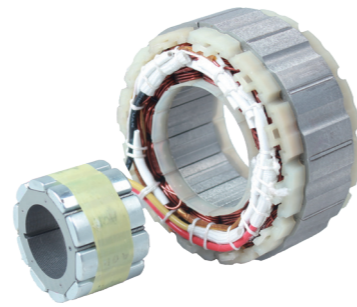

选件 Options



接插件

● 特性概要

(General Specifications)

绕组连接方式 (Winding Type)	星形 (Star connection)
介电强度 (Dielectric Strength)	600VAC/1S
绝缘电阻 (Insulation Resistance)	100MΩ, 500VDC
环境温度 (Ambient Temperature)	-20°C ~ +50°C
绝缘等级 (Insulation Class)	Class B

● 接线说明

(Electric Connection)

引出线颜色 Color	引出线型号 Type	功能 Functions
黄色 (Yellow)	AWG22	U相 (Phase U)
红色 (Red)		V相 (Phase V)
黑色 (Black)		W相 (Phase W)

● 电性能

(Electrical Specifications)

	单位 (Unit)	FL52MSV15
极数 (Number of poles)		10
相数 (Number of phases)		3
额定电压 (Rated voltage)	VDC	48
额定转矩 (Rated torque)	N.m	0.25
额定电流 (Rated current)	A	2.5
额定速度 (Rated speed)	RPM	3800
额定功率 (Rated power)	W	100
最大转速 (Maximum speed)	RPM	4700
峰值扭矩 (Peak torque)	N.m	0.75
峰值电流 (Peak current)	A	7.5
线电阻 (Line to line resistance)	ohms@20°C	1.65
线电感 (Line to line inductance)	mH	2.5
转矩常数 (Torque constant)	Nm/A	0.12
反电势 (Back EMF)	Vrms/KRPM	7.2
机身长度 (Motor length)	mm	26
电气时间常数 (Electrical time constant)	ms	1.52

● 性能曲线

(Performance Curve)

FL52MSV15-48V-3810

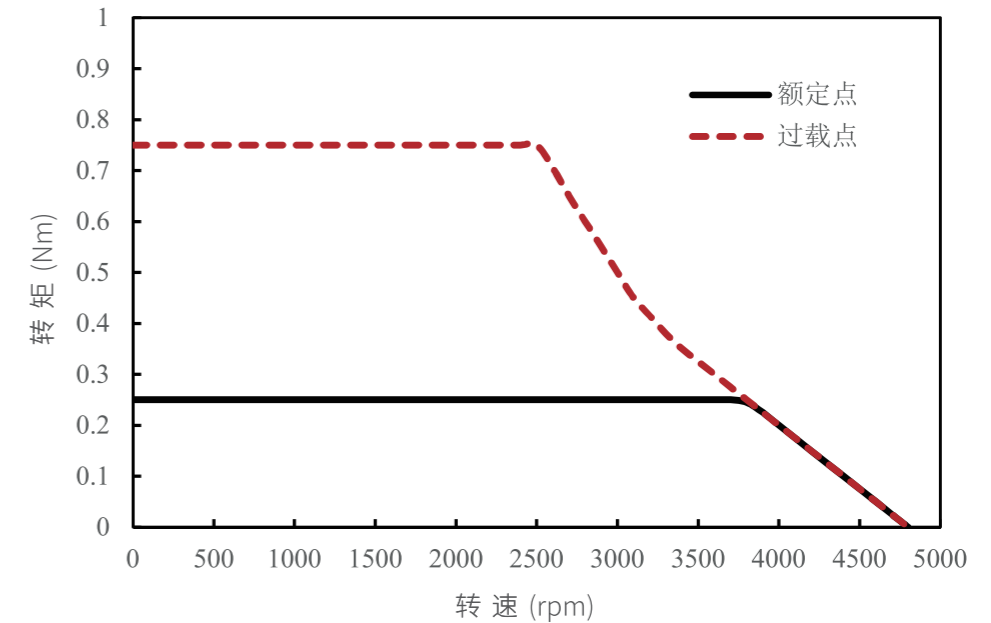

● 机械尺寸

(Dimensions)

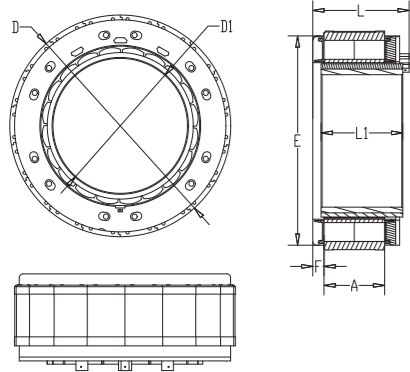

项目(Items)	FL60MSV16	公差(Tolerance)
定子外径D	60mm	js9
定子长度L	30.2mm	±1
转子内径D1	17mm	H8
转子长度L1	18mm	±0.25
骨架外圆E	57mm	±0.2

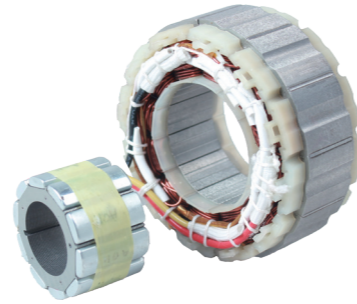

选件 Options



接插件

● 特性概要

(General Specifications)

绕组连接方式 (Winding Type)	星形 (Star connection)
介电强度 (Dielectric Strength)	600VAC/1S
绝缘电阻 (Insulation Resistance)	100MΩ, 500VDC
环境温度 (Ambient Temperature)	-20°C ~ +50°C
绝缘等级 (Insulation Class)	Class B

● 接线说明

(Electric Connection)

引出线颜色 Color	引出线型号 Type	功能 Functions
黄色 (Yellow)	AWG20	U相 (Phase U)
红色 (Red)		V相 (Phase V)
黑色 (Black)		W相 (Phase W)

● 电性能

(Electrical Specifications)

	单位 (Unit)	FL60MSV16
极数 (Number of poles)		10
相数 (Number of phases)		3
额定电压 (Rated voltage)	VDC	48
额定转矩 (Rated torque)	N.m	0.5
额定电流 (Rated current)	A	5
额定速度 (Rated speed)	RPM	3100
额定功率 (Rated power)	W	162
最大转速 (Maximum speed)	RPM	4200
峰值扭矩 (Peak torque)	N.m	1.5
峰值电流 (Peak current)	A	18
线电阻 (Line to line resistance)	ohms@20°C	0.3
线电感 (Line to line inductance)	mH	0.9
转矩常数 (Torque constant)	Nm/A	0.14
反电势 (Back EMF)	Vrms/KRPM	8.4
机身长度 (Motor length)	mm	30.2
电气时间常数 (Electrical time constant)	ms	3

● 性能曲线

(Performance Curve)

FL60MSV16-48V-3116

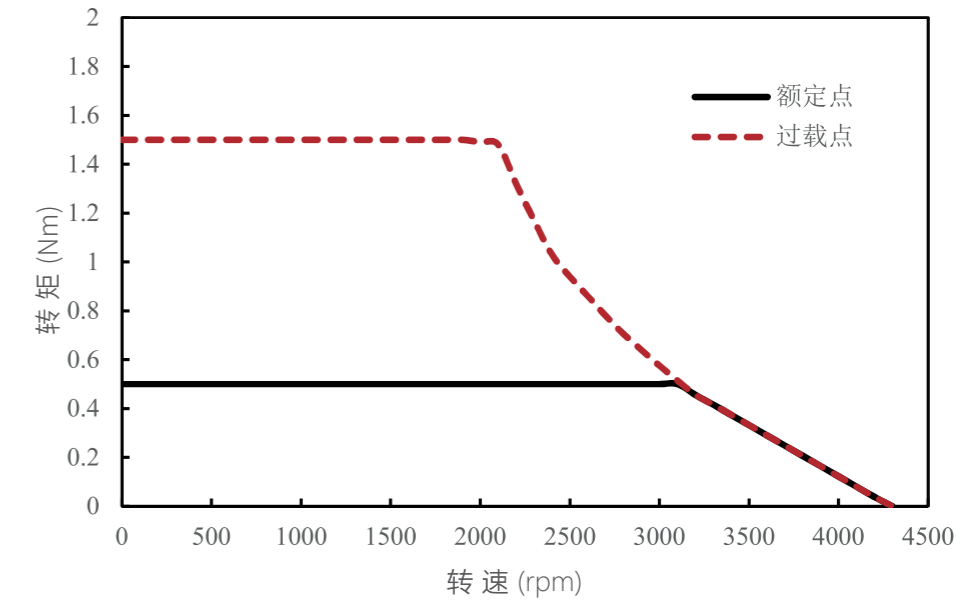

T-N曲线

● 机械尺寸

(Dimensions)

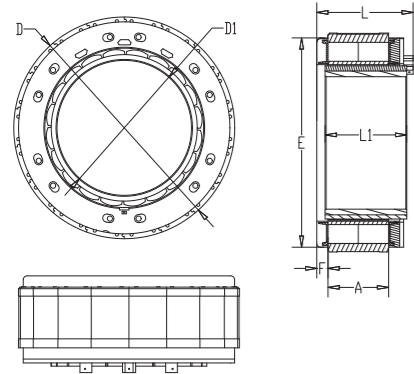

项目(Items)	FL77MSV20	公差(Tolerance)
定子外径D	77mm	js9
定子长度L	36mm	±1
转子内径D1	25mm	H8
转子长度L1	22mm	±0.25
骨架外圆E	74mm	±0.2

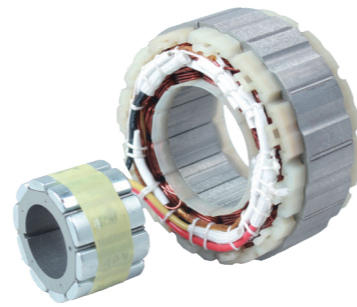

选件 Options



接插件

● 特性概要

(General Specifications)

绕组连接方式 (Winding Type)	星形 (Star connection)
介电强度 (Dielectric Strength)	600VAC/1S
绝缘电阻 (Insulation Resistance)	100MΩ, 500VDC
环境温度 (Ambient Temperature)	-20°C ~ +50°C
绝缘等级 (Insulation Class)	Class B

● 接线说明

(Electric Connection)

引出线颜色 Color	引出线型号 Type	功能 Functions
黄色 (Yellow)	AWG18	U相 (Phase U)
红色 (Red)		V相 (Phase V)
黑色 (Black)		W相 (Phase W)

● 电性能

(Electrical Specifications)

	单位 (Unit)	FL77MSV20
极数 (Number of poles)		10
相数 (Number of phases)		3
额定电压 (Rated voltage)	VDC	48
额定转矩 (Rated torque)	N.m	1
额定电流 (Rated current)	A	8.5
额定速度 (Rated speed)	RPM	3000
额定功率 (Rated power)	W	315
最大转速 (Maximum speed)	RPM	4000
峰值扭矩 (Peak torque)	N.m	2.5
峰值电流 (Peak current)	A	22
线电阻 (Line to line resistance)	ohms@20°C	0.188
线电感 (Line to line inductance)	mH	0.97
转矩常数 (Torque constant)	Nm/A	0.14
反电势 (Back EMF)	Vrms/KRPM	8.8
机身长度 (Motor length)	mm	36
电气时间常数 (Electrical time constant)	ms	5.15

● 性能曲线

(Performance Curve)

FL77MSV20-48V-3031

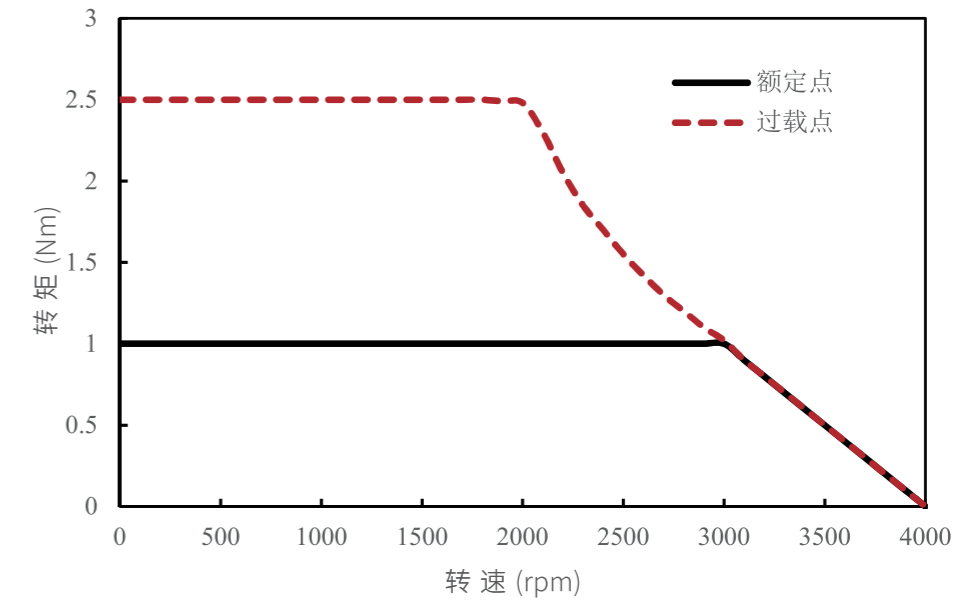

T-N曲线

● 机械尺寸

(Dimensions)

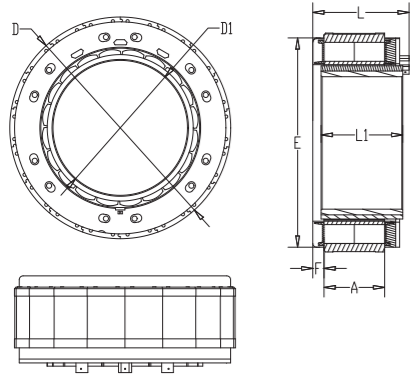

项目(Items)	FL96MSV21	公差(Tolerance)
定子外径D	96mm	js9
定子长度L	37mm	±1
转子内径D1	38mm	H8
转子长度L1	21.4mm	±0.25
骨架外圆E	92mm	±0.2

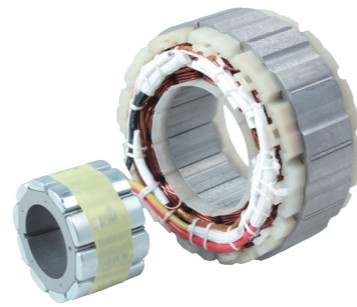

选件 Options



接插件

● 特性概要

(General Specifications)

绕组连接方式 (Winding Type)	星形 (Star connection)
介电强度 (Dielectric Strength)	600VAC/1S
绝缘电阻 (Insulation Resistance)	100MΩ, 500VDC
环境温度 (Ambient Temperature)	-20°C ~ +50°C
绝缘等级 (Insulation Class)	Class B

● 接线说明

(Electric Connection)

引出线颜色 Color	引出线型号 Type	功能 Functions
黄色 (Yellow)	AWG16	U相 (Phase U)
红色 (Red)		V相 (Phase V)
黑色 (Black)		W相 (Phase W)

● 电性能

(Electrical Specifications)

	单位 (Unit)	FL96MSV21
极数 (Number of poles)		10
相数 (Number of phases)		3
额定电压 (Rated voltage)	VDC	48
额定转矩 (Rated torque)	N.m	2
额定电流 (Rated current)	A	20
额定速度 (Rated speed)	RPM	3600
额定功率 (Rated power)	W	700
最大转速 (Maximum speed)	RPM	4500
峰值转矩 (Peak torque)	N.m	4
峰值电流 (Peak current)	A	45
线电阻 (Line to line resistance)	ohms@20°C	0.08
线电感 (Line to line inductance)	mH	0.4
转矩常数 (Torque constant)	Nm/A	0.13
反电势 (Back EMF)	Vrms/KRPM	7.8
机身长度 (Motor length)	mm	37
电气时间常数 (Electrical time constant)	ms	5

● 性能曲线

(Performance Curve)

FL96MSV21-48V-3670

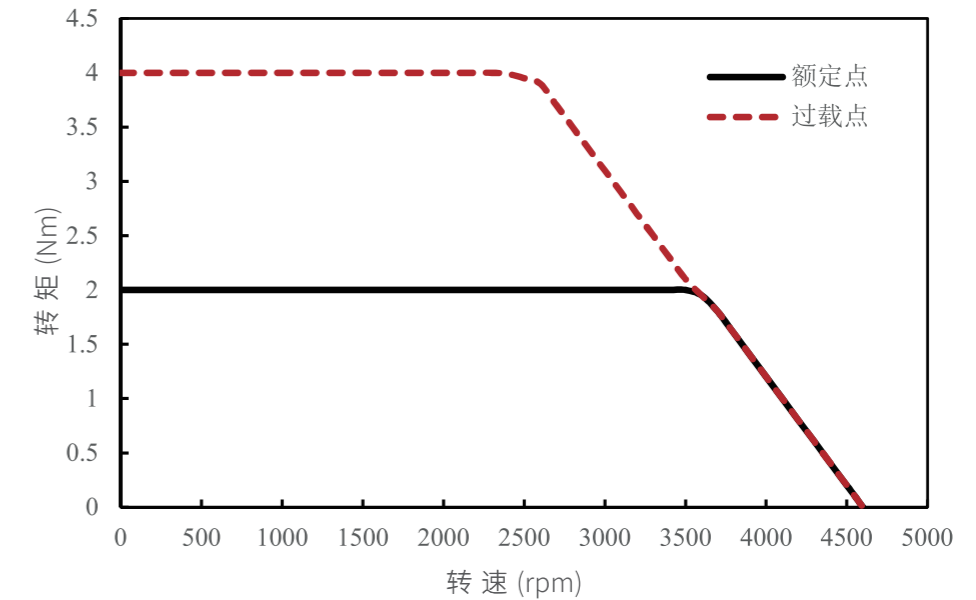

T-N曲线

● 机械尺寸

(Dimensions)

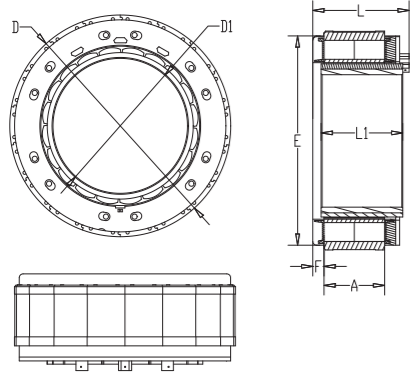

项目(Items)	FL122MSV34	公差(Tolerance)
定子外径D	122mm	js9
定子长度L	65mm	±1
转子内径D1	45mm	H8
转子长度L1	36mm	±0.25
骨架外圆E	119mm	±0.2

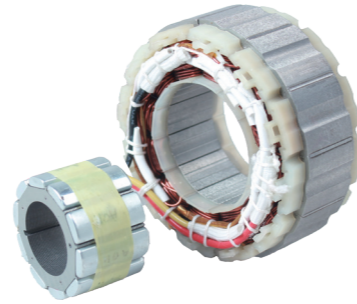

选件 Options



接插件

● 特性概要

(General Specifications)

绕组连接方式 (Winding Type)	星形 (Star connection)
介电强度 (Dielectric Strength)	600VAC/1S
绝缘电阻 (Insulation Resistance)	100MΩ, 500VDC
环境温度 (Ambient Temperature)	-20°C ~ +50°C
绝缘等级 (Insulation Class)	Class B

● 接线说明

(Electric Connection)

引出线颜色 Color	引出线型号 Type	功能 Functions
黄色 (Yellow)	AWG14	U相 (Phase U)
红色 (Red)		V相 (Phase V)
黑色 (Black)		W相 (Phase W)

● 电性能

(Electrical Specifications)

	单位 (Unit)	FL122MSV34
极数 (Number of poles)		10
相数 (Number of phases)		3
额定电压 (Rated voltage)	VDC	48
额定转矩 (Rated torque)	N.m	3.8
额定电流 (Rated current)	A	24
额定速度 (Rated speed)	RPM	2400
额定功率 (Rated power)	W	960
最大转速 (Maximum speed)	RPM	3000
峰值扭矩 (Peak torque)	N.m	9.5
峰值电流 (Peak current)	A	60
线电阻 (Line to line resistance)	ohms@20°C	0.045
线电感 (Line to line inductance)	mH	0.24
转矩常数 (Torque constant)	Nm/A	0.18
反电势 (Back EMF)	Vrms/KRPM	10.7
机身长度 (Motor length)	mm	65
电气时间常数 (Electrical time constant)	ms	6.3

● 性能曲线

(Performance Curve)

FL122MSV34-48V-2496

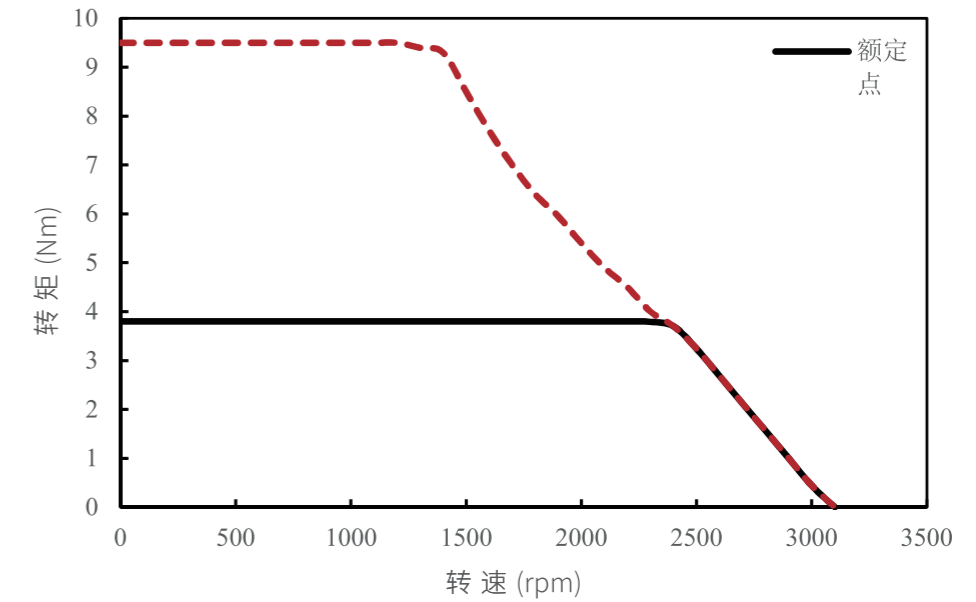

T-N曲线

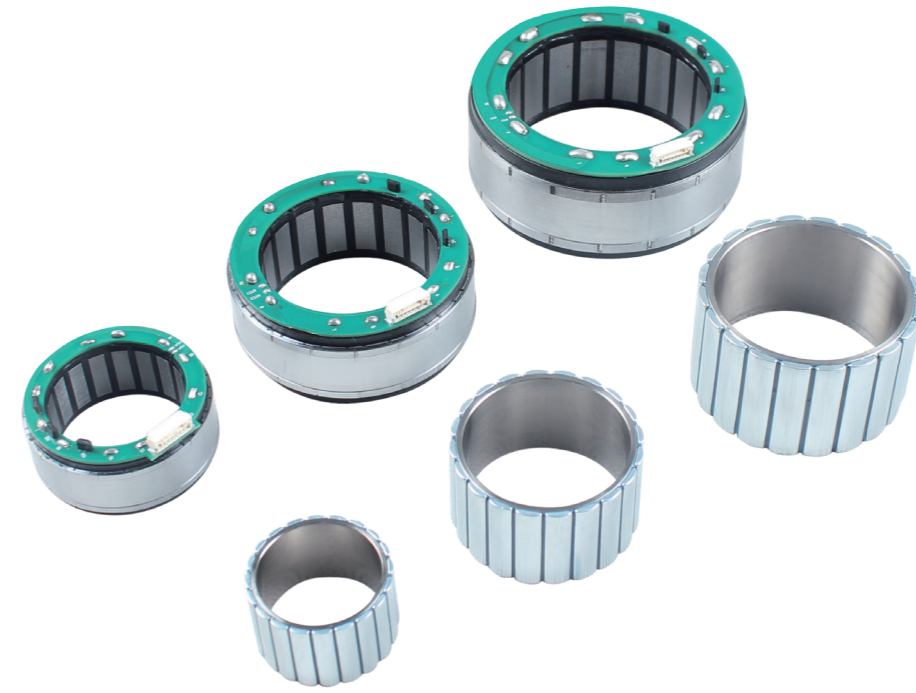

◎可适应最流行的嵌入式设备和协作机器人(cobot) 设计

Can be adaptable for the most popular design of embedded equipment and cooperative robot (cobot) .

◎ 专为在 48 伏及以下直流电压下工作而设计

Designed for operation at or below 48 VDC.

◎ 可选集成式霍尔传感器且不增加长度

Optional integrated hall sensor without increasing the length.

◎ 在不超过 85°C 的条件下性能最佳，但在高达 155°C 的绕组温度下依然能够连续充分维持性能表现。

Motor gets best performance at or below 85°C and is still able to continuously maintain full performance when winding temperatures up to 155°C.



注意事项:本样册中所有信息均为参考值。因检测和测量方法不同,可能存在偏差。请直接联系我们,以了解详细信息。我们原则上保留技术变更的权利。

Attentions: All figures are approximate values. Variations are possible and may arise for example due to non-standardized inspection and measurement methods. For more detailed information, please contact us directly. Fulling Motor company always reserves the right to make technical modifications.